



E-ISSN: 2708-3977
 P-ISSN: 2708-3969
 IJEDC 2023; 4(1): 01-08
 © 2023 IJEDC
www.datacomjournal.com
 Received: 02-10-2022
 Accepted: 09-11-2022

EL Pankratov
 Nizhny Novgorod State
 University, 23 Gagarin
 Avenue, Nizhny Novgorod,
 Russia

On optimization of manufacturing of MOSFET-filters to increase integration rate of their elements

EL Pankratov

Abstract

In this paper we introduce an approach to increase integration rate of elements in a MOSFET-filter. The approach based on decreasing of dimension of elements of the inverter (diodes and bipolar transistors) due to manufacturing of these elements by diffusion or ion implantation in a heterostructure with specific configuration and optimization of annealing of dopant and radiation defects.

Keywords: MOSFET-filter, optimization of manufacturing, analytical approach for prognosis

Introduction

In the present time one can find increasing of density of elements of integrated circuits due to increasing of density of their dimensions and optimization of technological processes. One can also find increasing of speed of these elements. One way to decrease dimensions of elements of integrated circuits is doping of required areas of materials by diffusion or ion implantations and using laser or microwave types of annealing [1-3]. Using these types of annealing leads to generation in homogenous distribution of temperature. In this situation one can find inhomogeneity of diffusion coefficient and another parameters of processes due to Arrhenius law. The inhomogeneity of these parameters gives a possibility to decrease dimensions of elements of integrated circuits. Another way to change properties of doped materials is radiation processing [4, 5]. An alternative approach to decrease dimensions of elements of integrated circuits is using inhomogeneity of heterostructures [6-9].

In this paper we consider a MOSFET-filter, which has been presented in the Figs. 1 [10]. The oscillator has been manufactured framework the heterostructure from Figs. 1. The heterostructure consist of a substrate and an epitaxial layer. The epitaxial layer includes into itself several sections, which were manufactured by using another materials. These sections were doped by diffusion or ion implantation to manufacture the required types of conductivity so as it is shown on Figs. 1. After this doping it is required annealing of dopant and/or radiation defects. Main aim of the present paper is analysis of redistribution of dopant and radiation defects to determine conditions, which correspond to decreasing of elements of the considered inverter and at the same time to increase their density.

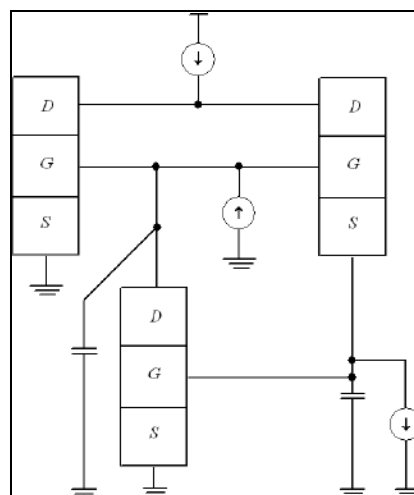

Fig 1a: Structure of the considered filter. View from top

Corresponding Author:
EL Pankratov
 Nizhny Novgorod State
 University, 23 Gagarin
 Avenue, Nizhny Novgorod,
 Russia

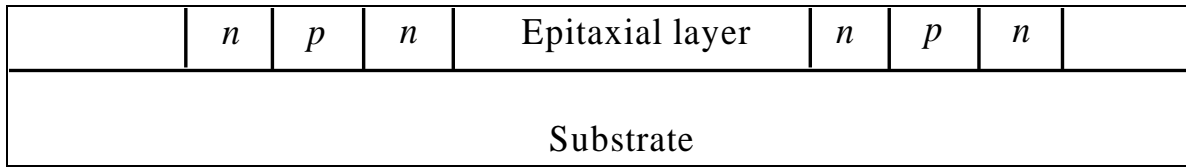

Fig 1b: Heterostructure with two layers and sections in the epitaxial layer

Method of solution

We determine spatio-temporal distribution of concentration of dopant by solving the following boundary problem

$$\frac{\partial C(x,y,z,t)}{\partial t} = \frac{\partial}{\partial x^2} \left[D_C \frac{\partial C(x,y,z,t)}{\partial x} \right] + \frac{\partial}{\partial y^2} \left[D_C \frac{\partial C(x,y,z,t)}{\partial y} \right] + \frac{\partial}{\partial z^2} \left[D_C \frac{\partial C(x,y,z,t)}{\partial z} \right] \tag{1}$$

With boundary and initial conditions

$$\frac{\partial C(x,y,z,t)}{\partial x} \Big|_{x=0} = 0, \frac{\partial C(x,y,z,t)}{\partial x} \Big|_{x=L_x} = 0, \frac{\partial C(x,y,z,t)}{\partial y} \Big|_{y=0} = 0, \tag{2}$$

$$\frac{\partial C(x,y,z,t)}{\partial y} \Big|_{y=L_y} = 0, \frac{\partial C(x,y,z,t)}{\partial z} \Big|_{z=0} = 0, \frac{\partial C(x,y,z,t)}{\partial z} \Big|_{z=L_z} = 0, C(x,y,z,0) = f(x,y,z).$$

Here $C(x,y,z,t)$ is the spatio-temporal distribution of concentration of dopant; T is the temperature of annealing; D_C is the dopant diffusion coefficient. Value of dopant diffusion coefficient depends on properties of materials, speed of heating and cooling of heterostructure (with account Arrhenius law). Dependences of dopant diffusion coefficients could be approximated by the following function [4, 11, 12].

$$D_C = D_L(x,y,z,T) \left[1 + \xi \frac{C^{\gamma}(x,y,z,t)}{P^{\gamma}(x,y,z,T)} \right] \left[1 + \zeta_1 \frac{V(x,y,z,t)}{V^*} + \zeta_2 \frac{V^2(x,y,z,t)}{(V^*)^2} \right], \tag{3}$$

where $D_L(x,y,z,T)$ is the spatial (due to existing several layers with different properties in heterostructure) and temperature (due to Arrhenius law) dependences of dopant diffusion coefficient; $P(x,y,z,T)$ is the limit of solubility of dopant; parameter γ could be integer framework the following interval $\gamma \in [1, 3, 11]$; $V(x,y,z,t)$ is the spatio-temporal distribution of concentration of radiation vacancies; V^* is the equilibrium distribution of concentration of vacancies. Concentrational dependence of dopant diffusion coefficient have been discussed in details in [11]. It should be noted, that using diffusion type of doping did not leads to generation radiation defects and $\zeta_1 = \zeta_2 = 0$. We determine spatio-temporal distributions of concentrations of point defects have been determine by solving the following system of equations [4, 12].

$$\begin{aligned} \frac{\partial I(x,y,z,t)}{\partial t} &= \frac{\partial}{\partial x} \left[D_I(x,y,z,T) \frac{\partial I(x,y,z,t)}{\partial x} \right] + \frac{\partial}{\partial y} \left[D_I(x,y,z,T) \frac{\partial I(x,y,z,t)}{\partial y} \right] + \\ &+ \frac{\partial}{\partial z} \left[D_I(x,y,z,T) \frac{\partial I(x,y,z,t)}{\partial z} \right] - k_{I,V}(x,y,z,T) I(x,y,z,t) V(x,y,z,t) - \\ &- k_{I,I}(x,y,z,T) I^2(x,y,z,t) \end{aligned} \tag{4}$$

$$\begin{aligned} \frac{\partial V(x,y,z,t)}{\partial t} &= \frac{\partial}{\partial x} \left[D_V(x,y,z,T) \frac{\partial V(x,y,z,t)}{\partial x} \right] + \frac{\partial}{\partial y} \left[D_V(x,y,z,T) \frac{\partial V(x,y,z,t)}{\partial y} \right] + \\ &+ \frac{\partial}{\partial z} \left[D_V(x,y,z,T) \frac{\partial V(x,y,z,t)}{\partial z} \right] - k_{I,V}(x,y,z,T) I(x,y,z,t) V(x,y,z,t) - \\ &- k_{V,V}(x,y,z,T) V^2(x,y,z,t) \end{aligned}$$

with boundary and initial conditions

$$\frac{\partial \rho(x,y,z,t)}{\partial x} \Big|_{x=0} = 0, \frac{\partial \rho(x,y,z,t)}{\partial x} \Big|_{x=L_x} = 0, \frac{\partial \rho(x,y,z,t)}{\partial y} \Big|_{y=0} = 0, \frac{\partial \rho(x,y,z,t)}{\partial y} \Big|_{y=L_y} = 0,$$

$$\frac{\partial \rho(x,y,z,t)}{\partial z} \Big|_{z=0} = 0, \frac{\partial \rho(x,y,z,t)}{\partial z} \Big|_{z=L_z} = 0, \rho(x,y,z,0) = f_{\rho}(x,y,z). \tag{5}$$

Here $\rho = I, V$; $I(x,y,z,t)$ is the spatio-temporal distribution of concentration of radiation interstitials; $D_{\rho}(x,y,z,T)$ is the diffusion

coefficients of radiation interstitials and vacancies; terms $V^2(x,y,z,t)$ and $I^2(x,y,z,t)$ correspond to generation of divacancies and diinterstitials; $k_{I,V}(x,y,z,T)$ is the parameter of recombination of point radiation defects; $k_{\rho,\rho}(x,y,z,T)$ are the parameters of generation of simplest complexes of point radiation defects.

We determine spatio-temporal distributions of concentrations of divacancies $\Phi_V(x,y,z,t)$ and diinterstitials $\Phi_I(x,y,z,t)$ by solving the following system of equations [11,12].

$$\begin{aligned} \frac{\partial \Phi_I(x,y,z,t)}{\partial t} &= \frac{\partial}{\partial x} \left[D_{\Phi_I}(x,y,z,T) \frac{\partial \Phi_I(x,y,z,t)}{\partial x} \right] + \frac{\partial}{\partial y} \left[D_{\Phi_I}(x,y,z,T) \frac{\partial \Phi_I(x,y,z,t)}{\partial y} \right] + \\ &+ \frac{\partial}{\partial z} \left[D_{\Phi_I}(x,y,z,T) \frac{\partial \Phi_I(x,y,z,t)}{\partial z} \right] + k_{I,I}(x,y,z,T) I^2(x,y,z,t) - k_I(x,y,z,T) I(x,y,z,t) \end{aligned} \quad (6)$$

$$\begin{aligned} \frac{\partial \Phi_V(x,y,z,t)}{\partial t} &= \frac{\partial}{\partial x} \left[D_{\Phi_V}(x,y,z,T) \frac{\partial \Phi_V(x,y,z,t)}{\partial x} \right] + \frac{\partial}{\partial y} \left[D_{\Phi_V}(x,y,z,T) \frac{\partial \Phi_V(x,y,z,t)}{\partial y} \right] + \\ &+ \frac{\partial}{\partial z} \left[D_{\Phi_V}(x,y,z,T) \frac{\partial \Phi_V(x,y,z,t)}{\partial z} \right] + k_{V,V}(x,y,z,T) V^2(x,y,z,t) - k_V(x,y,z,T) V(x,y,z,t) \end{aligned}$$

with boundary and initial conditions

$$\begin{aligned} \left. \frac{\partial \Phi_\rho(x,y,z,t)}{\partial x} \right|_{x=0} &= 0, \left. \frac{\partial \Phi_\rho(x,y,z,t)}{\partial x} \right|_{x=L_x} = 0, \left. \frac{\partial \Phi_\rho(x,y,z,t)}{\partial y} \right|_{y=0} = 0, \\ \left. \frac{\partial \Phi_\rho(x,y,z,t)}{\partial y} \right|_{y=L_y} &= 0, \left. \frac{\partial \Phi_\rho(x,y,z,t)}{\partial z} \right|_{z=0} = 0, \left. \frac{\partial \Phi_\rho(x,y,z,t)}{\partial z} \right|_{z=L_z} = 0, \end{aligned} \quad (7)$$

$$\Phi_I(x,y,z,0) = f\phi_I(x,y,z), \quad \Phi_V(x,y,z,0) = f\phi_V(x,y,z).$$

Here $D_{\Phi_\rho}(x,y,z,T)$ are the diffusion coefficients of complexes of radiation defects; $k_{\rho}(x,y,z,T)$ are the parameters of decay of complexes of radiation defects.

We determine spatio-temporal distributions of concentrations of dopant and radiation defects by using method of averaging of function corrections [13] with decreased quantity of iteration steps [14]. Framework the approach we used solutions of Eqs. (1), (4) and (6) in linear form and with averaged values of diffusion coefficients $D_{0L}, D_{0I}, D_{0V}, D_{0\phi I}, D_{0\phi V}$ as initial-order approximations of the required concentrations. The solutions could be written as

$$C_1(x,y,z,t) = \frac{F_{0C}}{L_x L_y L_z} + \frac{2}{L_x L_y L_z} \sum_{n=1}^{\infty} F_{nC} c_n(x) c_n(y) c_n(z) e_{nC}(t),$$

$$I_1(x,y,z,t) = \frac{F_{0I}}{L_x L_y L_z} + \frac{2}{L_x L_y L_z} \sum_{n=1}^{\infty} F_{nI} c_n(x) c_n(y) c_n(z) e_{nI}(t),$$

$$V_1(x,y,z,t) = \frac{F_{0V}}{L_x L_y L_z} + \frac{2}{L_x L_y L_z} \sum_{n=1}^{\infty} F_{nV} c_n(x) c_n(y) c_n(z) e_{nV}(t),$$

$$\Phi_{I1}(x,y,z,t) = \frac{F_{0\Phi I}}{L_x L_y L_z} + \frac{2}{L_x L_y L_z} \sum_{n=1}^{\infty} F_{n\Phi I} c_n(x) c_n(y) c_n(z) e_{n\Phi I}(t),$$

$$\Phi_{V1}(x,y,z,t) = \frac{F_{0\Phi V}}{L_x L_y L_z} + \frac{2}{L_x L_y L_z} \sum_{n=1}^{\infty} F_{n\Phi V} c_n(x) c_n(y) c_n(z) e_{n\Phi V}(t),$$

where $e_{n\rho}(t) = \exp \left[-\pi^2 n^2 D_{0\rho} t \left(\frac{1}{L_x^2} + \frac{1}{L_y^2} + \frac{1}{L_z^2} \right) \right]$, $F_{n\rho} = \int_0^{L_x} c_n(u) \int_0^{L_y} c_n(v) \int_0^{L_z} c_n(w) f_\rho(u,v,w) dw dv du$, $c_n(\chi) = \cos(\pi n \chi / L_\chi)$.

The second-order approximations and approximations with higher orders of concentrations of dopant and radiation defects we determine framework standard iterative procedure [13, 14]. Framework this procedure to calculate approximations with the n -order one shall replace the functions $C(x,y,z,t), I(x,y,z,t), V(x,y,z,t), \Phi_I(x,y,z,t), \Phi_V(x,y,z,t)$ in the right sides of the Eqs. (1), (4) and (6) on the following sums $\alpha_{n\rho+\rho} \alpha_{n-1}(x,y,z,t)$. As an example we present equations for the second-order approximations of the considered concentrations.

$$\begin{aligned} \frac{\partial C_2(x,y,z,t)}{\partial t} &= \frac{\partial}{\partial x} \left(\left[1 + \zeta_1 \frac{V(x,y,z,t)}{V^*} + \zeta_2 \frac{V^2(x,y,z,t)}{(V^*)^2} \right] \left\{ 1 + \xi \frac{[\alpha_{2C} + C_1(x,y,z,t)]^y}{P^y(x,y,z,T)} \right\} \times \right. \\ &\times D_L(x,y,z,T) \frac{\partial C_1(x,y,z,t)}{\partial x} \Big) + \frac{\partial}{\partial x} \left(D_L(x,y,z,T) \left[1 + \zeta_1 \frac{V(x,y,z,t)}{V^*} + \zeta_2 \frac{V^2(x,y,z,t)}{(V^*)^2} \right] \times \right. \end{aligned}$$

$$\begin{aligned} & \times \left\{ 1 + \xi \frac{[\alpha_{2C} + C_1(x,y,z,t)]^Y}{P^Y(x,y,z,T)} \right\} \frac{\partial C_1(x,y,z,t)}{\partial y} \Big) + \frac{\partial}{\partial \tau^2} \left(D_L(x,y,z,T) \frac{\partial C_1(x,y,z,t)}{\partial z} \times \right. \\ & \times \left. \left[1 + \zeta_1 \frac{V(x,y,z,t)}{V^*} + \zeta_2 \frac{V^2(x,y,z,t)}{(V^*)^2} \right] \left\{ 1 + \xi \frac{[\alpha_{2C} + C_1(x,y,z,t)]^Y}{P^Y(x,y,z,T)} \right\} \right) \end{aligned} \quad (8)$$

$$\begin{aligned} & \left\{ \frac{\partial I_2(x,y,z,t)}{\partial \tau} = \frac{\partial}{\partial x} \left[D_I(x,y,z,T) \frac{\partial I_1(x,y,z,t)}{\partial x} \right] + \frac{\partial}{\partial y} \left[D_I(x,y,z,T) \frac{\partial I_1(x,y,z,t)}{\partial y} \right] + \right. \\ & + \frac{\partial}{\partial z} \left[D_I(x,y,z,T) \frac{\partial I_1(x,y,z,t)}{\partial z} \right] - [\alpha_{2I} + I_1(x,y,z,t)] [\alpha_{2V} + V_1(x,y,z,t)] \times \\ & \times k_{I,V}(x,y,z,T) - k_{I,I}(x,y,z,T) [\alpha_{2I} + I_1(x,y,z,t)]^2 \\ & \left. \frac{\partial V_2(x,y,z,t)}{\partial \tau} = \frac{\partial}{\partial x} \left[D_V(x,y,z,T) \frac{\partial V_1(x,y,z,t)}{\partial x} \right] + \frac{\partial}{\partial y} \left[D_V(x,y,z,T) \frac{\partial V_1(x,y,z,t)}{\partial y} \right] + \right. \\ & + \frac{\partial}{\partial z} \left[D_V(x,y,z,T) \frac{\partial V_1(x,y,z,t)}{\partial z} \right] - [\alpha_{2I} + I_1(x,y,z,t)] [\alpha_{2V} + V_1(x,y,z,t)] \times \\ & \times k_{I,V}(x,y,z,T) - k_{V,V}(x,y,z,T) [\alpha_{2V} + V_1(x,y,z,t)]^2 \end{aligned} \quad (9)$$

$$\begin{aligned} & \left\{ \frac{\partial \Phi_{I_2}(x,y,z,t)}{\partial \tau} = \frac{\partial}{\partial x} \left[D_{\Phi_I}(x,y,z,T) \frac{\partial \Phi_{I_1}(x,y,z,t)}{\partial x} \right] + \frac{\partial}{\partial y} \left[D_{\Phi_I}(x,y,z,T) \times \right. \right. \\ & \times \frac{\partial \Phi_{I_1}(x,y,z,t)}{\partial y} \Big] + \frac{\partial}{\partial z} \left[D_{\Phi_I}(x,y,z,T) \frac{\partial \Phi_{I_1}(x,y,z,t)}{\partial z} \right] + k_{I,I}(x,y,z,T) \times \\ & \times I^2(x,y,z,t) - k_I(x,y,z,T) I(x,y,z,t) \\ & \left. \frac{\partial \Phi_{V_2}(x,y,z,t)}{\partial \tau} = \frac{\partial}{\partial x} \left[D_{\Phi_V}(x,y,z,T) \frac{\partial \Phi_{V_1}(x,y,z,t)}{\partial x} \right] + \frac{\partial}{\partial y} \left[D_{\Phi_V}(x,y,z,T) \times \right. \right. \\ & \times \frac{\partial \Phi_{V_1}(x,y,z,t)}{\partial y} \Big] + \frac{\partial}{\partial z} \left[D_{\Phi_V}(x,y,z,T) \frac{\partial \Phi_{V_1}(x,y,z,t)}{\partial z} \right] + k_{V,V}(x,y,z,T) \times \\ & \times V^2(x,y,z,t) - k_V(x,y,z,T) V(x,y,z,t) \end{aligned} \quad (10)$$

Integration of the left and right sides of Eqs.(8)-(10) gives us possibility to obtain relations for the second-order approximations of concentrations of dopant and radiation defects in final form

$$\begin{aligned} C_2(x,y,z,t) &= \frac{\partial}{\partial \tau^2} \left(\int_0^t \left[1 + \zeta_1 \frac{V(x,y,z,\tau)}{V^*} + \zeta_2 \frac{V^2(x,y,z,\tau)}{(V^*)^2} \right] \left\{ 1 + \xi \frac{[\alpha_{2C} + C_1(x,y,z,\tau)]^Y}{P^Y(x,y,z,T)} \right\} \times \right. \\ & \times D_L(x,y,z,T) \frac{\partial C_1(x,y,z,\tau)}{\partial x} \Big) d\tau + \frac{\partial}{\partial \tau^2 y} \left(\int_0^t \left[1 + \zeta_1 \frac{V(x,y,z,\tau)}{V^*} + \zeta_2 \frac{V^2(x,y,z,\tau)}{(V^*)^2} \right] \times \right. \\ & \times D_L(x,y,z,T) \left\{ 1 + \xi \frac{[\alpha_{2C} + C_1(x,y,z,\tau)]^Y}{P^Y(x,y,z,T)} \right\} \frac{\partial C_1(x,y,z,\tau)}{\partial y} d\tau \Big) + \frac{\partial}{\partial \tau^2 z} \left(\int_0^t D_L(x,y,z,T) \times \right. \\ & \times \left. \left[1 + \zeta_1 \frac{V(x,y,z,\tau)}{V^*} + \zeta_2 \frac{V^2(x,y,z,\tau)}{(V^*)^2} \right] \left\{ 1 + \xi \frac{[\alpha_{2C} + C_1(x,y,z,\tau)]^Y}{P^Y(x,y,z,T)} \right\} \frac{\partial C_1(x,y,z,\tau)}{\partial z} d\tau \right) + \\ & + f_C(x,y,z) \quad (8a) \end{aligned}$$

$$\begin{aligned} I_2(x,y,z,t) &= \frac{\partial}{\partial x} \left[\int_0^t D_I(x,y,z,T) \frac{\partial I_1(x,y,z,\tau)}{\partial x} d\tau \right] + \frac{\partial}{\partial y} \left[\int_0^t D_I(x,y,z,T) \times \right. \\ & \times \frac{\partial I_1(x,y,z,\tau)}{\partial y} d\tau \Big] + \frac{\partial}{\partial z} \left[\int_0^t D_I(x,y,z,T) \frac{\partial I_1(x,y,z,\tau)}{\partial z} d\tau \right] - \int_0^t k_{I,I}(x,y,z,T) \times \\ & \times [\alpha_{2I} + I_1(x,y,z,\tau)]^2 d\tau + f_I(x,y,z) - \int_0^t k_{I,V}(x,y,z,T) [\alpha_{2I} + I_1(x,y,z,\tau)] \times \\ & \times [\alpha_{2V} + V_1(x,y,z,\tau)] d\tau \quad (9a) \end{aligned}$$

$$\begin{aligned} V_2(x,y,z,t) &= \frac{\partial}{\partial x} \left[\int_0^t D_V(x,y,z,T) \frac{\partial V_1(x,y,z,\tau)}{\partial x} d\tau \right] + \frac{\partial}{\partial y} \left[\int_0^t D_V(x,y,z,T) \times \right. \\ & \times \frac{\partial V_1(x,y,z,\tau)}{\partial y} d\tau \Big] + \frac{\partial}{\partial z} \left[\int_0^t D_V(x,y,z,T) \frac{\partial V_1(x,y,z,\tau)}{\partial z} d\tau \right] - \int_0^t k_{V,V}(x,y,z,T) \times \\ & \times [\alpha_{2I} + V_1(x,y,z,\tau)]^2 d\tau + f_V(x,y,z) - \int_0^t k_{I,V}(x,y,z,T) [\alpha_{2I} + I_1(x,y,z,\tau)] \times \\ & \times [\alpha_{2V} + V_1(x,y,z,\tau)] d\tau \end{aligned}$$

$$\Phi_{I_2}(x,y,z,t) = \frac{\partial}{\partial x} \left[\int_0^t D_{\Phi_I}(x,y,z,T) \frac{\partial \Phi_{I_1}(x,y,z,\tau)}{\partial x} d\tau \right] + \frac{\partial}{\partial y} \left[\int_0^t D_{\Phi_I}(x,y,z,T) \times \right.$$

$$\times \frac{\partial \phi_{I1}(x,y,z,\tau)}{\partial y} d\tau \Big] + \frac{\partial}{\partial z} \left[\int_0^t D_{\phi_I}(x,y,z,T) \frac{\partial \phi_{I1}(x,y,z,\tau)}{\partial z} d\tau \right] + \int_0^t k_{I,I}(x,y,z,T) \times \\ \times I^2(x,y,z,\tau) d\tau - \int_0^t k_I(x,y,z,T) I(x,y,z,\tau) d\tau + f_{\phi_I}(x,y,z) \quad (10a)$$

$$\phi_{V2}(x,y,z,t) = \frac{\partial}{\partial x} \left[\int_0^t D_{\phi_V}(x,y,z,T) \frac{\partial \phi_{V1}(x,y,z,\tau)}{\partial x} d\tau \right] + \frac{\partial}{\partial y} \left[\int_0^t D_{\phi_V}(x,y,z,T) \times \right. \\ \times \frac{\partial \phi_{I1}(x,y,z,\tau)}{\partial y} d\tau \Big] + \frac{\partial}{\partial z} \left[\int_0^t D_{\phi_V}(x,y,z,T) \frac{\partial \phi_{V1}(x,y,z,\tau)}{\partial z} d\tau \right] + \int_0^t k_{V,V}(x,y,z,T) \times \\ \times V^2(x,y,z,\tau) d\tau - \int_0^t k_V(x,y,z,T) V(x,y,z,\tau) d\tau + f_{\phi_V}(x,y,z)$$

We determine average values of the second-orders approximations of the considered concentrations by using the following standard relations [13, 14].

$$\alpha_{2\rho} = \frac{1}{\theta L_x L_y L_z} \int_0^\theta \int_0^{L_x} \int_0^{L_y} \int_0^{L_z} [\rho_2(x,y,z,t) - \rho_1(x,y,z,t)] dz dy dx dt. \quad (11)$$

Substitution of relations (8a)-(10a) into relation (11) gives us possibility to obtain relations for the required average values $\alpha_{2\rho}$

$$\alpha_{2C} = \frac{1}{L_x L_y L_z} \int_0^{L_x} \int_0^{L_y} \int_0^{L_z} f_C(x,y,z) dz dy dx, \quad (12)$$

$$\alpha_{2I} = \frac{1}{2A_{II00}} \{ (1 + A_{IV01} + A_{II10} + \alpha_{2V} A_{IV00})^2 - 4A_{II00} [\alpha_{2V} A_{IV10} - A_{II20} + A_{IV11} - \\ - \frac{1}{L_x L_y L_z} \int_0^{L_x} \int_0^{L_y} \int_0^{L_z} f_I(x,y,z) dz dy dx] \}^{\frac{1}{2}} - \frac{1 + A_{IV01} + A_{II10} + \alpha_{2V} A_{IV00}}{2A_{II00}} \quad (13a)$$

$$\alpha_{2V} = \frac{1}{2B_4} \sqrt{\frac{(B_2 + A)^2}{4} - 4B_4 \left(y + \frac{B_2 y - B_1}{A} \right) - \frac{B_2 + A}{4B_4}}, \quad (13b)$$

Where, $A_{abij} = \frac{1}{\theta L_x L_y L_z} \int_0^\theta (\theta - t) \int_0^{L_x} \int_0^{L_y} \int_0^{L_z} k_{a,b}(x,y,z,T) I_1^i(x,y,z,t) V_1^j(x,y,z,t) dz dy dx dt,$

$$B_4 = A_{IV00}^2 A_{IV00}^2 - 2(A_{IV00}^2 - A_{II00} A_{VV00})^2, B_3 = A_{IV00} A_{IV00}^2 + A_{IV01} A_{IV00}^3 + A_{IV00} A_{II10} A_{IV00}^2 - \\ - 4(A_{IV00}^2 - A_{II00} A_{VV00}) [2A_{IV01} A_{IV00} + 2A_{IV00} (1 + A_{IV01} + A_{II10}) - 2A_{II00} (A_{IV10} + A_{VV10} + 1)] - \\ - 4A_{IV10} A_{II00} A_{IV00}^2 + 2A_{IV00} A_{IV01} A_{IV00}^2, B_2 = A_{IV00}^2 \{ (1 + A_{IV01} + A_{II10})^2 + A_{IV00}^2 A_{IV01}^2 + A_{IV00} \times \\ \times 2A_{IV00} (A_{IV00} + A_{IV00} A_{IV01} + A_{IV00} A_{II10} - 4A_{IV10} A_{II00}) - 4A_{II00} \left[A_{IV11} - A_{II20} - \frac{1}{L_x L_y L_z} \times \right. \\ \times \int_0^{L_x} \int_0^{L_y} \int_0^{L_z} f_I(x,y,z) dz dy dx \Big] \} \{ [2A_{IV01} A_{IV00} + 2A_{IV00} (1 + A_{IV01} + A_{II10}) - 2A_{II00} (A_{IV10} + 1 + \\ + A_{VV10})]^2 + 2 \left[A_{IV01} (1 + A_{IV01} + A_{II10}) + \frac{2}{L_x L_y L_z} \int_0^{L_x} \int_0^{L_y} \int_0^{L_z} f_V(x,y,z) dz dy dx - 2A_{II00} (A_{VV20} - \right. \\ - A_{IV11}) + A_{IV01} (1 + A_{IV01} + A_{II10}) \} [2A_{IV00} (1 + A_{IV01} + A_{II10}) + 2A_{IV01} A_{IV00} - 2A_{II00} (A_{IV10} + 1 + \\ + A_{VV10}) \}, B_1 = 2A_{IV00} A_{IV01} (1 + A_{IV01} + A_{II10})^2 - 8 \left[A_{IV11} - \frac{1}{L_x} \int_0^{L_x} \int_0^{L_y} \int_0^{L_z} f_I(x,y,z) dz dy dx \times \right. \\ \times \frac{1}{L_y L_z} - A_{II20} \Big] + A_{IV00} A_{IV01} A_{II00} + A_{IV01}^2 (A_{IV00} + A_{IV00} A_{IV01} + A_{IV00} A_{II10} - 4A_{IV10} A_{II00}) - \\ - 2 \left[\frac{2A_{II00}}{L_x L_y L_z} \int_0^{L_x} \int_0^{L_y} \int_0^{L_z} f_I(x,y,z) dz dy dx + A_{IV01} (1 + A_{IV01} + A_{II10}) - 2A_{II00} (A_{VV20} - A_{IV11}) + \right. \\ \left. + A_{IV01} (1 + A_{IV01} + A_{II10}) \right] [2A_{IV00} (1 + A_{IV01} + A_{II10}) - 2(A_{IV10} + A_{VV10} + 1) A_{II00} + 2A_{IV01} A_{IV00}],$$

$$\begin{aligned}
 B_0 &= 4A_{II00}A_{IV01}^2 \left[A_{II20} + \frac{1}{L_x L_y L_z} \int_0^{L_x} \int_0^{L_y} \int_0^{L_z} f_I(x, y, z) dz dy dx - A_{IV11} \right] + A_{IV01}^2 (A_{IV01} + A_{II10} + \\
 &+ 1)^2 - \left[\frac{2A_{II00}}{L_x L_y L_z} \int_0^{L_x} \int_0^{L_y} \int_0^{L_z} f_V(x, y, z) dz dy dx + A_{IV01} (1 + A_{IV01} + A_{II10}) - 2A_{II00} (A_{VV20} - A_{IV11}) + \right. \\
 &+ A_{IV01} (1 + A_{IV01} + A_{II10}) \left. \right]^2, y = \sqrt[3]{\sqrt{q^2 + p^3} - q} - \sqrt[3]{\sqrt{q^2 + p^3} + q} + \frac{B_2}{6}, q = (2B_1 B_3 - 8B_0) \times \\
 &\times \frac{B_2}{48} + \frac{B_2^2}{216} + \frac{B_0(4B_2 - B_2^2) - B_1^2}{8}, p = [3(2B_1 B_3 - 8B_0) - 2B_2^2]/72, A = \sqrt{8y + B_3^2 - 4B_2}, \\
 \alpha_{2\Phi_I} &= A_{II20} - \frac{1}{\theta L_x L_y L_z} \int_0^\theta (\theta - t) \int_0^{L_x} \int_0^{L_y} \int_0^{L_z} k_I(x, y, z, T) I(x, y, z, t) dz dy dx dt + \\
 &+ \frac{1}{L_x L_y L_z} \int_0^{L_x} \int_0^{L_y} \int_0^{L_z} f_{\Phi_I}(x, y, z) dz dy dx \tag{14} \\
 \alpha_{2\Phi_V} &= A_{VV20} - \frac{1}{\theta L_x L_y L_z} \int_0^\theta (\theta - t) \int_0^{L_x} \int_0^{L_y} \int_0^{L_z} k_V(x, y, z, T) V(x, y, z, t) dz dy dx dt + \\
 &+ \frac{1}{L_x L_y L_z} \int_0^{L_x} \int_0^{L_y} \int_0^{L_z} f_{\Phi_V}(x, y, z) dz dy dx.
 \end{aligned}$$

The considered substitution gives us possibility to obtain equation for parameter α_{2C} . Solution of the equation depends on value of parameter γ . Analysis of spatio-temporal distributions of concentrations of dopant and radiation defects has been done by using their second-order approximations framework the method of averaged of function corrections with decreased quantity of iterative steps. The second-order approximation is usually enough good approximation to make qualitative analysis and obtain some quantitative results. Results of analytical calculation have been checked by comparison with results of numerical simulation.

Discussion

In this section we analyzed spatio-temporal distribution of concentration of infused (see Fig. 2a) and implanted (see Fig. 2b) dopants in the considered epitaxial layer. Annealing time is the same for the each curve framework each figure. Increasing of number of curve corresponds to increasing of difference between values of dopant diffusion coefficient in layers of heterostructure. The figures show, that interface between layers of heterostructure gives a possibility to increase absolute value of gradient of concentration of dopant in direction, which is perpendicular to the interface. In this situation one can find decreasing of dimensions of diodes and transistors framework the considered inverter. At the same time with increasing of absolute value of the above gradient one can find increasing homogeneity of distribution of concentrations of dopants in dope d areas.

To choose annealing time it is necessary to take into account decreasing of absolute value of gradient of concentration of dopant near interface between epitaxial layer and substrate with increasing of value of annealing time. Decreasing of value of annealing time leads to increasing of inhomogeneity of distribution of concentration of dopant (see Figs. 3a for diffusion type of doping and 3b for ion type of doping). We determine the compromise value of annealing time framework recently introduced criterion [15-20]. Framework the criterion we approximate real distribution of concentration of dopant by idealized step-wise function $\psi(x, y, z)$. After that we determine the required compromise value of annealing time by minimization of the mean-squared error

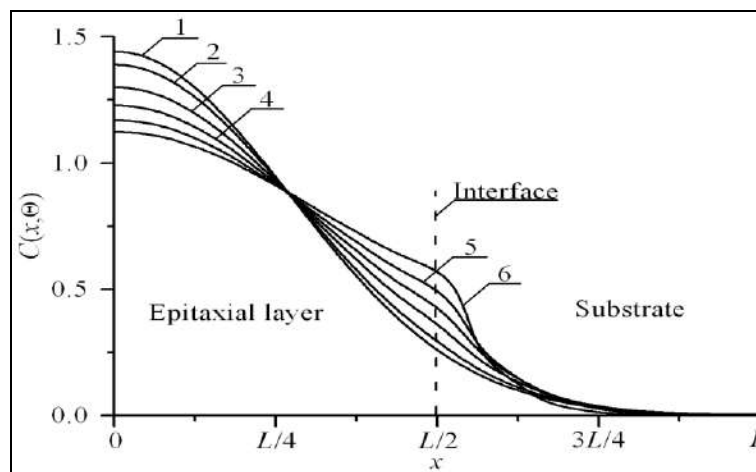

Fig 2a: Distributions of concentration of infused dopant in heterostructure from Figs. 1 and 2 in direction, which is perpendicular to interface between epitaxial layer substrate. Increasing of number of curve corresponds to increasing of difference between values of dopant diffusion coefficient in layers of heterostructure under condition, when value of dopant diffusion coefficient in epitaxial layer is larger, than value of dopant diffusion coefficient in substrate

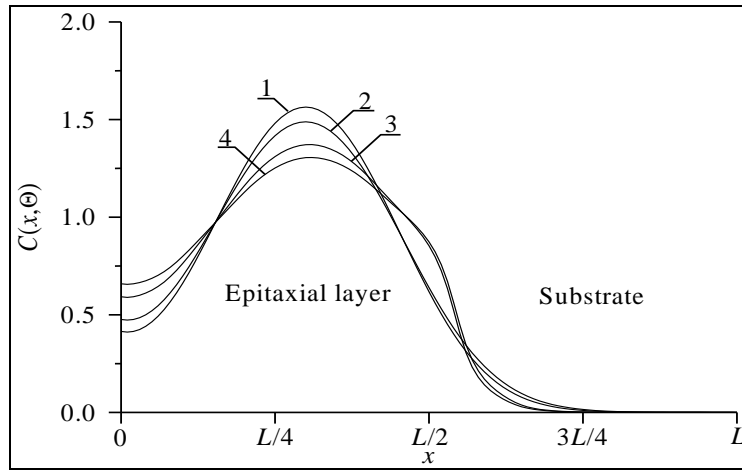

Fig 2b: Distributions of concentration of implanted dopant in heterostructure from Figs. 1 and 2 in direction, which is perpendicular to interface between epitaxial layer substrate. Curves 1 and 3 corresponds to annealing time $\Theta = 0.0048(L_x^2 + L_y^2 + L_z^2)/D_0$. Curves 2 and 4 corresponds to annealing time $\Theta = 0.0057(L_x^2 + L_y^2 + L_z^2)/D_0$. Curves 1 and 2 corresponds to homogenous sample. Curves 3 and 4 corresponds to heterostructure under condition, when value of dopant diffusion coefficient in epitaxial layer is larger, than value of dopant diffusion coefficient in substrate

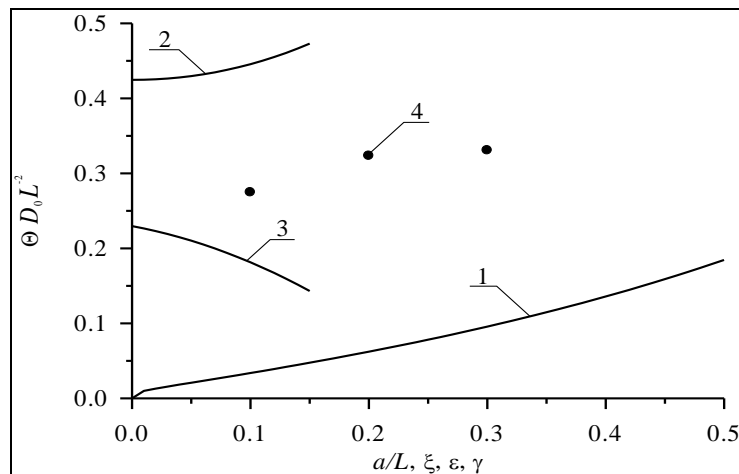

Fig 3a: Dependences of dimensionless optimal annealing time for doping by diffusion, which have been obtained by minimization of mean-squared error, on several parameters. Curve 1 is the dependence of dimensionless optimal annealing time on the relation a/L and $\xi = \gamma = 0$ for equal to each other values of dopant diffusion coefficient in all parts of heterostructure. Curve 2 is the dependence of dimensionless optimal annealing time on value of parameter ε for $a/L=1/2$ and $\xi = \gamma = 0$. Curve 3 is the dependence of dimensionless optimal annealing time on value of parameter ξ for $a/L=1/2$ and $\varepsilon = \gamma = 0$. Curve 4 is the dependence of dimensionless optimal annealing time on value of parameter γ for $a/L=1/2$ and $\varepsilon = \xi = 0$

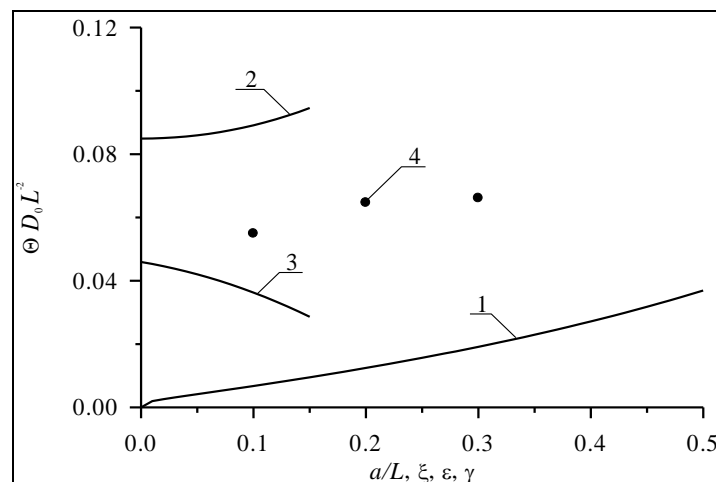

Fig 3b: Dependences of dimensionless optimal annealing time for doping by ion implantation, which have been obtained by minimization of mean-squared error, on several parameters. Curve 1 is the dependence of dimensionless optimal annealing time on the relation a/L and $\xi = \gamma = 0$ for equal to each other values of dopant diffusion coefficient in all parts of heterostructure. Curve 2 is the dependence of dimensionless optimal annealing time on value of parameter ε for $a/L=1/2$ and $\xi = \gamma = 0$. Curve 3 is the dependence of dimensionless optimal annealing time on value of parameter ξ for $a/L=1/2$ and $\varepsilon = \gamma = 0$. Curve 4 is the dependence of dimensionless optimal annealing time on value of parameter γ for $a/L=1/2$ and $\varepsilon = \xi = 0$

$$U = \frac{1}{L_x L_y L_z} \int_0^{L_x} \int_0^{L_y} \int_0^{L_z} [C(x, y, z, \theta) - \psi(x, y, z)] dz dy dx. \quad (8)$$

Dependences of optimal annealing time are presented on Figs. 3 for diffusion and ion types of doping, respectively. It should be noted, that it is necessary to anneal radiation defects after ion implantation. One could find spreading of concentration of distribution of dopant during this annealing. In the ideal case distribution of dopant achieves appropriate interfaces between materials of heterostructure during annealing of radiation defects. If dopant did not achieves any interfaces during annealing of radiation defects, it is practically to additionally anneal the dopant. In this situation optimal value of additional annealing time of implanted dopant is smaller, than annealing time of infused dopant. At the same time ion type of doping gives us possibility to decrease mismatch-induced stress in heterostructure [21].

Conclusion

In this paper we model redistribution of infused and implanted dopants during manufacturing a MOSFET-filter based on field-effect heterotransistors. Several recommendations to optimize manufacture the heterotransistors have been formulated. Analytical approach to model diffusion and ion types of doping with account concurrent changing of parameters in space and time has been introduced. At the same time the approach gives us possibility to take into account nonlinearity of doping processes.

References

1. Ong KK, Pey KL, Lee PS, Wee ATS, Wang XC, Chong YF. *Appl. Phys. Lett.* 2006;89(17):172111.
2. Wang HT, Tan LS, Chor EF. *J Appl. Phys.* 2006;98(9):094901.
3. Yu Bykov V, Yermeev AG, Zharova NA, Plotnikov IV, Rybakov KI, Drozdov MN, *et al.* *Radiophysics and Quantum Electronics.* 2003;43(3):836.
4. Kozlivsky VV. *Modification of semiconductors by proton beams*, Nauka, Sant-Peterburg; c2003.
5. Vinetskiy VL, Kholodar' GA. *Radiative physics of semiconductors.* Naukova Dumka, Kiev; c1979.
6. Volovich G. *Modern Electronics*, 2006, 2(10).
7. Kerentsev A, Lanin V, *Power Electronics*, 2008, 1(34).
8. Ageev AO, Belyaev AE, Boltovets NS, Ivanov VN, Konakova RV, Kudrik Ya Ya, *et al.* *Semiconductors.* 2009;43(7):897.
9. Volokobinskaya NI, Komarov IN, Matyukhina TV, Reshetnikov VI, Rush AA, Falina IV, *et al.* *Semiconductors.* 2001;35(8):1013.
10. Metin B, Cicekoglu O, Ozoguz S. *Analog integrated circuits and signal processing.* 2018;97(1):5-13.
11. Yu Gotra Z. *Technology of microelectronic devices*, Radio and communication, Moscow; c1991.
12. Fahey PM, Griffin PB, Plummer JD. *Rev. Mod. Phys.* 1989;61(2):289.
13. Yu Sokolov D. *Applied Mechanics.* 1955;1(1):23.
14. Pankratov EL. *The European Physical Journal B.* 2007;57(3):251.
15. Pankratov EL. *Russian Microelectronics.* 2007;36(1):33.
16. Pankratov EL. *Int. J Nanoscience.* 2008;7(4-5):187.
17. Pankratov EL. *J. Comp. Theor. Nanoscience.* 2010;7(1):289-295.
18. Pankratov EL, Bulaeva EA. *J Comp. Theor. Nanoscience.* 2013;10(4):888-893.
19. Pankratov EL, Bulaeva EA. *Int. J Micro-Nano Scale Transp.* 2014;4(1):17-31.
20. Pankratov EL, Bulaeva EA. *Int. J Nanoscience.* 2012;11(5):1250028-1250035.
21. Pankratov EL, Bulaeva EA. *J Comp. Theor. Nanoscience.* 2014;11(1):91-101.